



Carbon Black De-Dusting

Removes Dust and Fines from Carbon Black Pellets

Derrick Corporation manufactures high quality vibrating screening machines and patented screen surfaces for the carbon black industry. High speed dry screening machines efficiently removes dust and oversize from pellets.

The Derrick high speed screen is designed to remove overs and fines from carbon black pellet streams without damaging the pellets.

DERRICK DE-DUSTING UNIT:

- One Moving Part
- Low Energy – 2 HP
- Dust Tight Unit
- Long Screen Life
- Stainless Steel Screens

FLOW RATES:

- Up to 7,000 lbs./hr. at 120 mesh

DE-DUST:

- Packaging Room
- Load-out
- Tank Storage

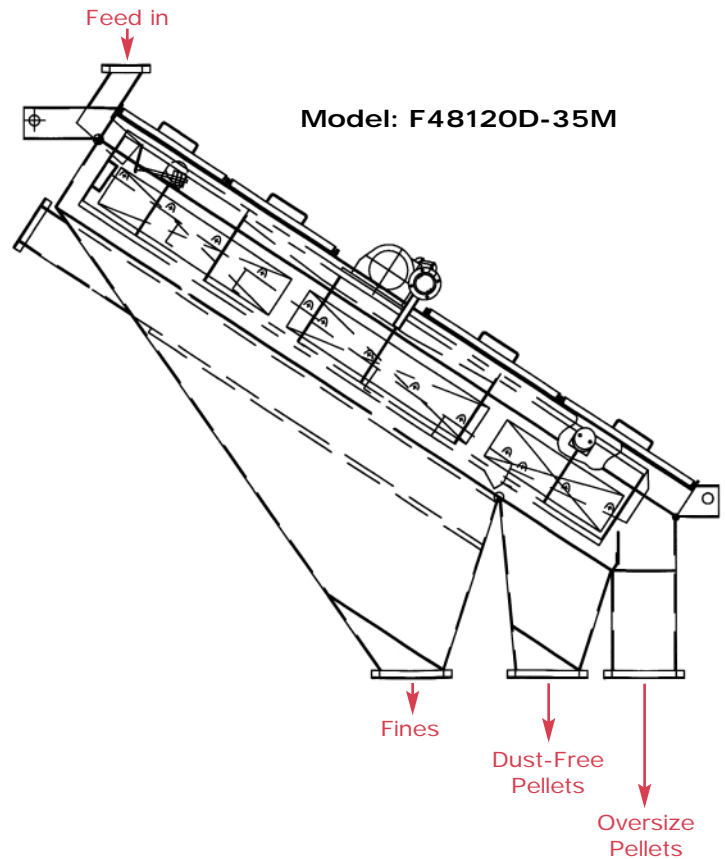

“Ship a Dust-Free Product to Your Customer”

FR122 - 10/02
Copyright ©2002 Derrick Corporation.
All products indicated by trademark symbols are trademarked and/or registered by Derrick Corporation.

Serving all our customers worldwide: www.derrickcorp.com

590 Duke Road • Buffalo, New York 14225
Phone: (716) 683-9010 • Fax: (716) 683-4991
E-mail: info@derrickcorp.com



The Established World Leader in Dry Screen Sizing